

NASPA Systems  
 110 Ashley Lakes Drive  
 Norcross, GA 30092

Title Akai Tape Deck

Size B Document Number Rev A

Date: Monday, December 03, 2001 Sheet 1 of 10

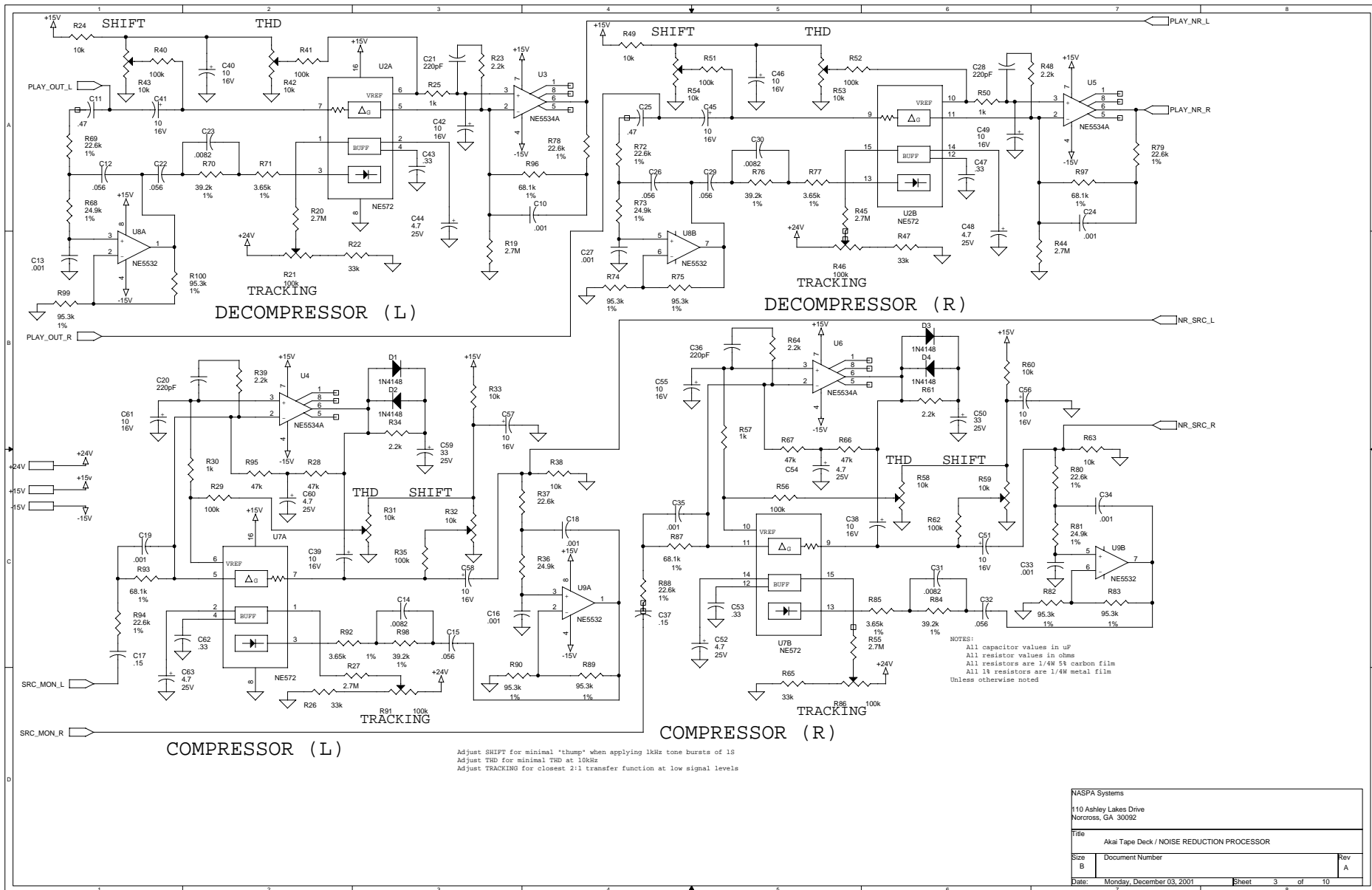

NASPA Systems		
110 Ashley Lakes Drive Norcross, GA 30092		
Title Akai Tape Deck / NOISE REDUCTION PROCESSOR		
Size B	Document Number	Rev A
Date Monday, December 03, 2001	Sheet 3	of 10

### ERASE HEAD

LEFT RIGHT

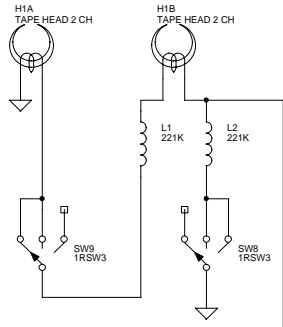

### RECORD HEAD

LEFT RIGHT

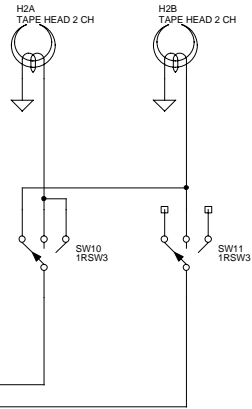

### PLAY HEAD

LEFT RIGHT

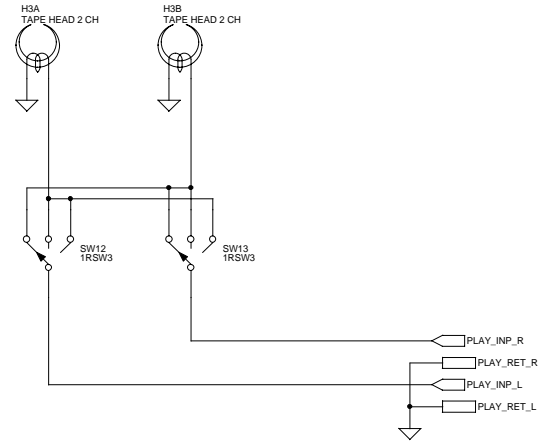

NASPA Systems 110 Ashley Lakes Drive Norcross, GA 30092		
Title Akai Tape Deck / HEAD ASSEMBLY		
Size B	Document Number	Rev A
Date Monday, December 03, 2001	Sheet 7	of 10

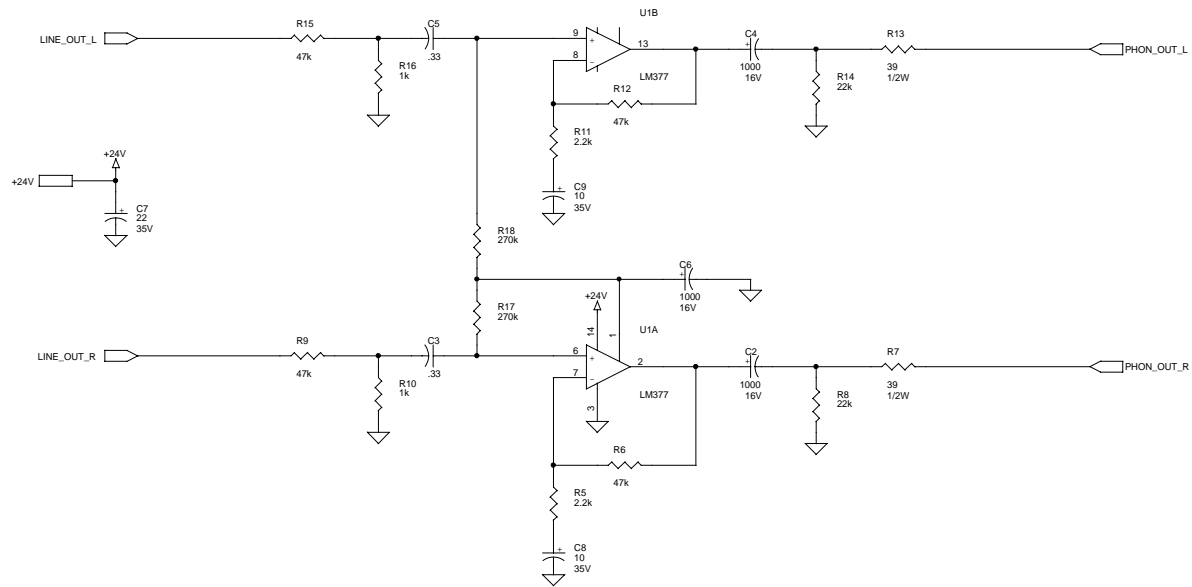

NOTES:  
 All capacitor values in uF  
 All resistor values in ohms  
 All resistors are 1/4W 5% carbon  
 Unless otherwise noted

NASPA Systems		
110 Ashley Lakes Drive Norcross, GA 30092		
Title Akai Tape Deck / HEADPHONE AMPLIFIER		
Size B	Document Number	Rev A
Date Monday, December 03, 2001	Sheet 2	of 10

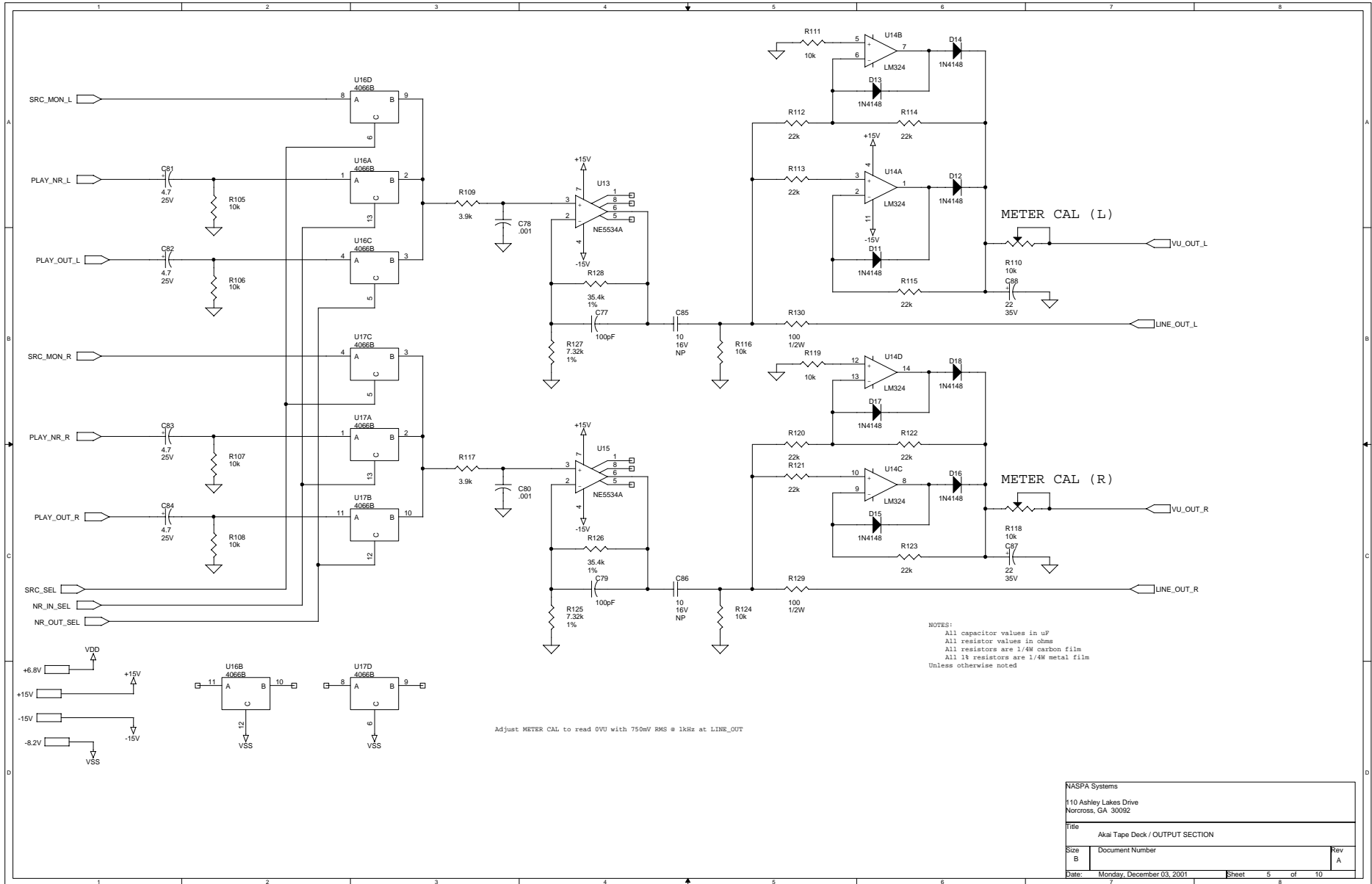

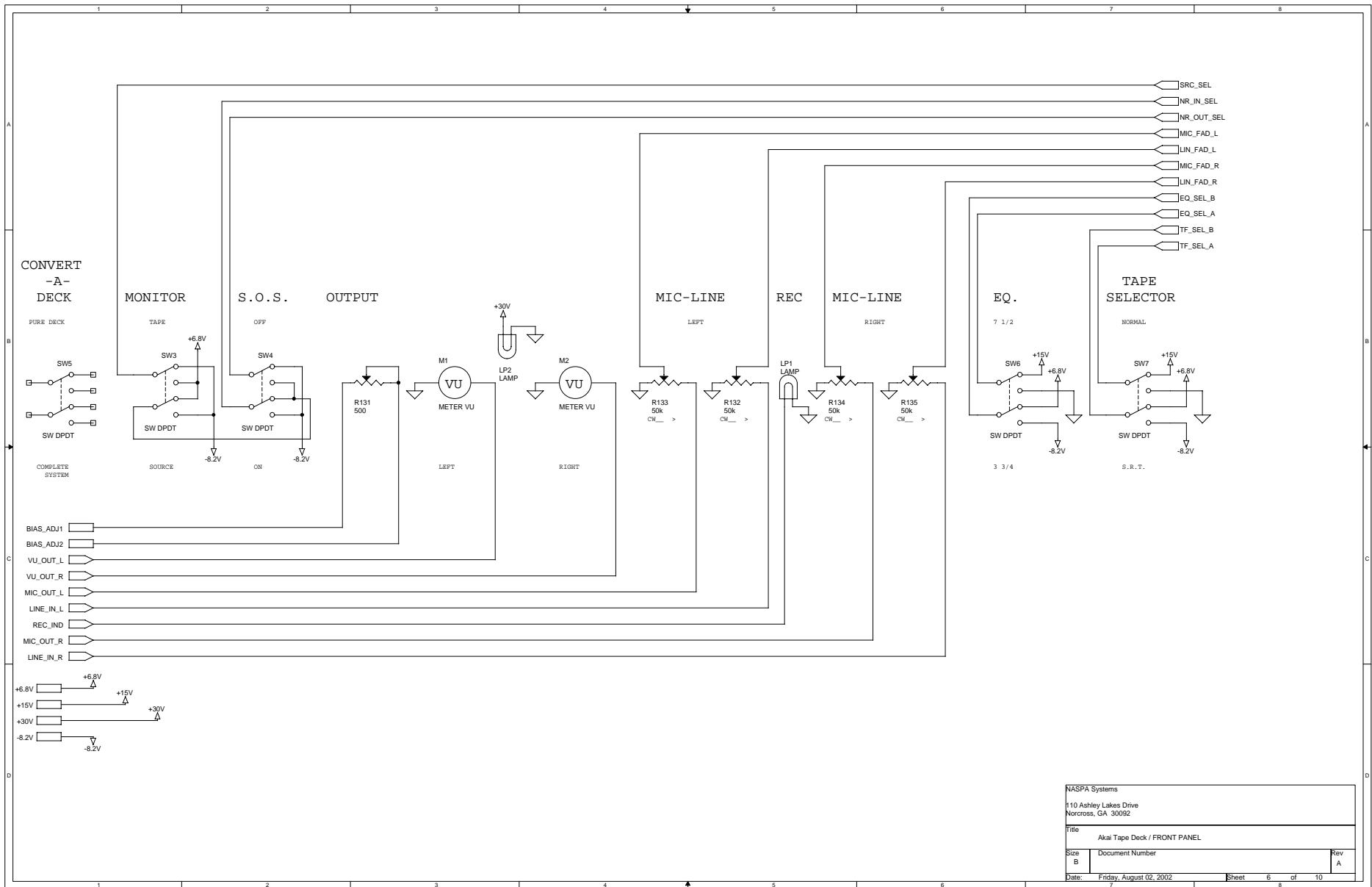

NASPA Systems 110 Ashley Lakes Drive Norcross, GA 30092		
Title Akai Tape Deck / FRONT PANEL		
Size B	Document Number	Rev A
Date: Friday, August 02, 2002      Sheet 6 of 10		

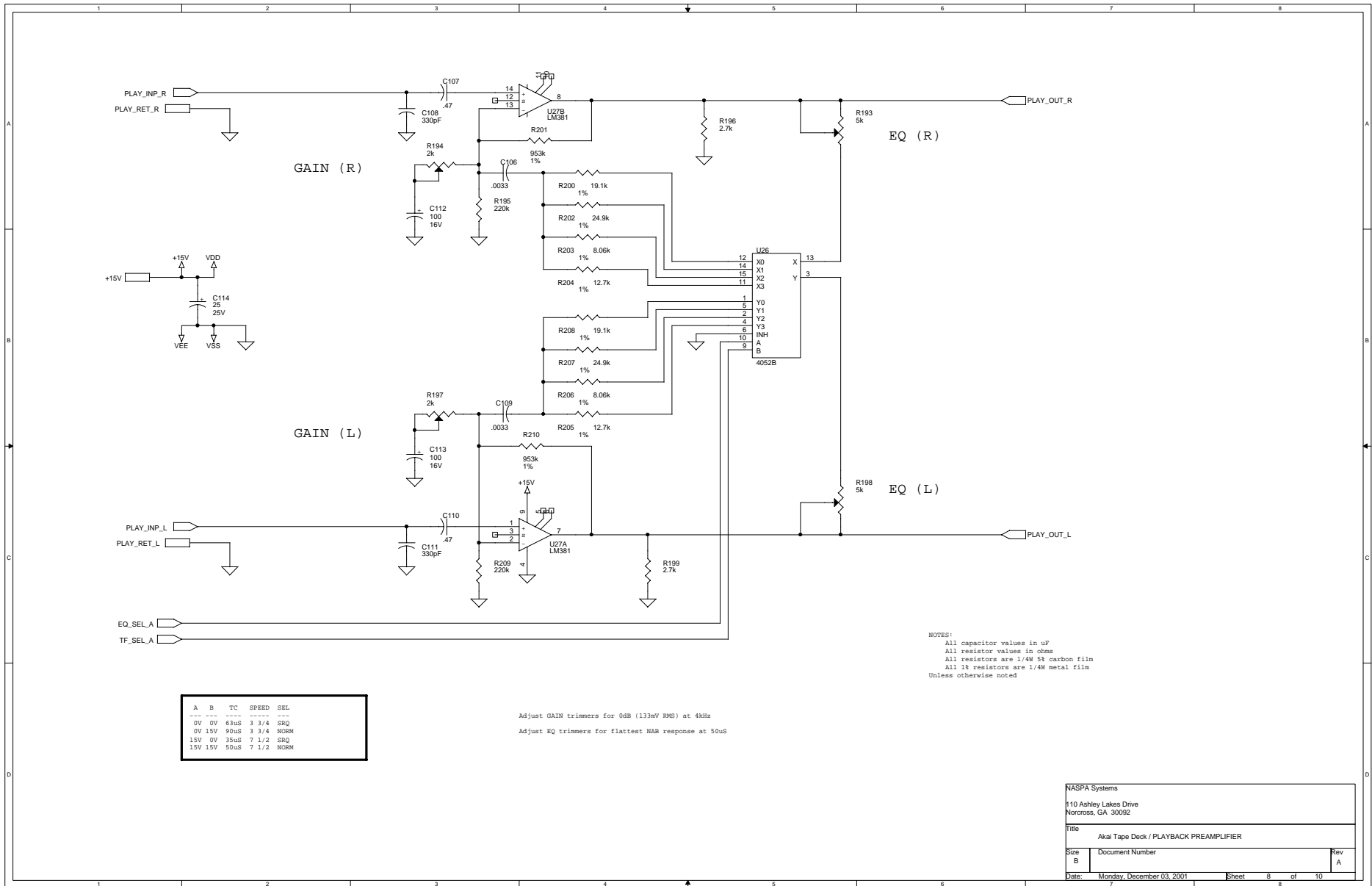

NOTES:  
 All capacitor values in µF  
 All resistor values in ohms  
 All resistors are 1/4W 5% carbon film  
 All 1% resistors are 1/4W metal film  
 Unless otherwise noted

A	B	TC	SPEED	SEL
0V	0V	63µs	3 3/4	SRQ
0V	15V	90µs	3 3/4	NORM
15V	0V	35µs	7 1/2	SRQ
15V	15V	50µs	7 1/2	NORM

Adjust GAIN trimmers for 0dB (133mV RMS) at 4kHz  
 Adjust EQ trimmers for flattest NAB response at 50µs

NASPA Systems		
110 Ashley Lakes Drive Norcross, GA 30092		
Title Akai Tape Deck / PLAYBACK PREAMPLIFIER		
Size B	Document Number	Rev A
Date Monday, December 03, 2001	Sheet 8	of 10

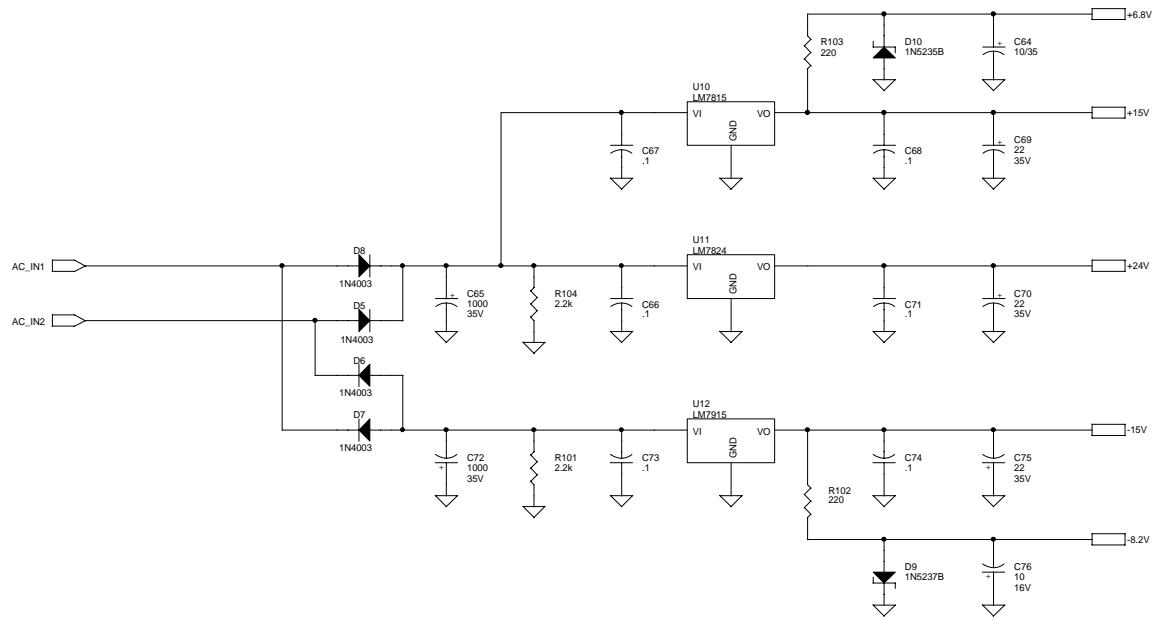

NOTES:  
 All capacitor values in uF  
 All resistor values in ohms  
 All resistors are 1/2W 5% carbon  
 Unless otherwise noted

NASPA Systems		
110 Ashley Lakes Drive Norcross, GA 30092		
Title Akai Tape Deck / POWER SUPPLY		
Size B	Document Number	Rev A
Date Monday, December 03, 2001	Sheet 4	of 10



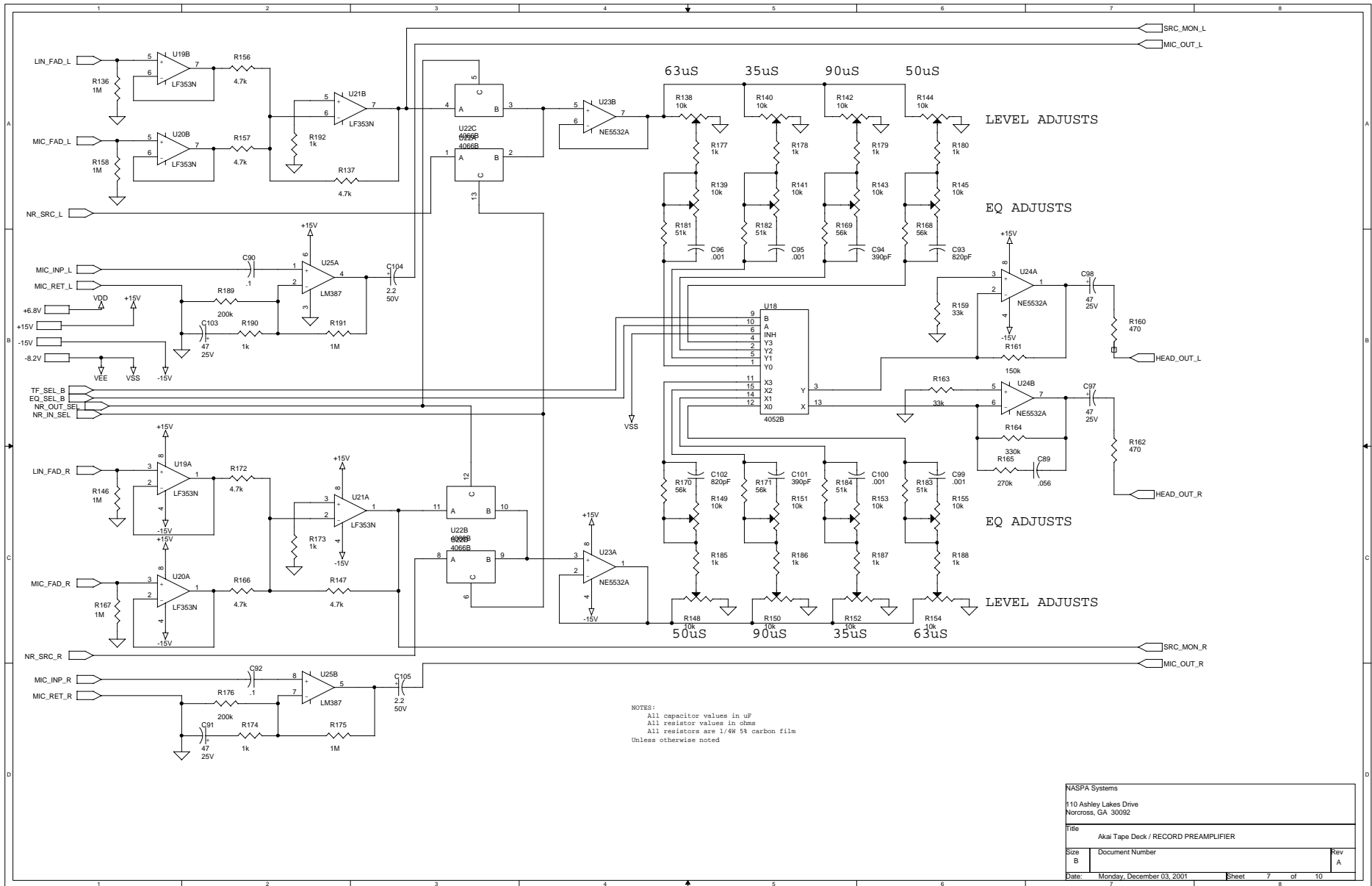

NOTES:  
 All capacitor values in  $\mu\text{F}$   
 All resistor values in ohms  
 All resistors are 1/4W 5% carbon film  
 Unless otherwise noted

NASPA Systems		
110 Ashley Lakes Drive Norcross, GA 30092		
Title Akai Tape Deck / RECORD PREAMPLIFIER		
Size B	Document Number	Rev A
Date Monday, December 03, 2001	Sheet 7	of 10